

PRODUCT NUMBER
SEE TABLE

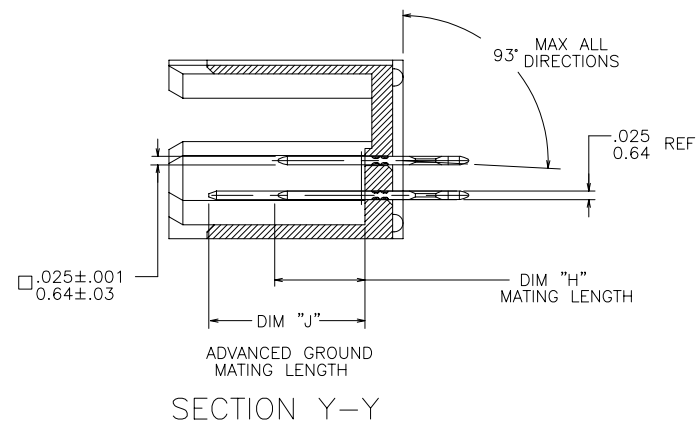
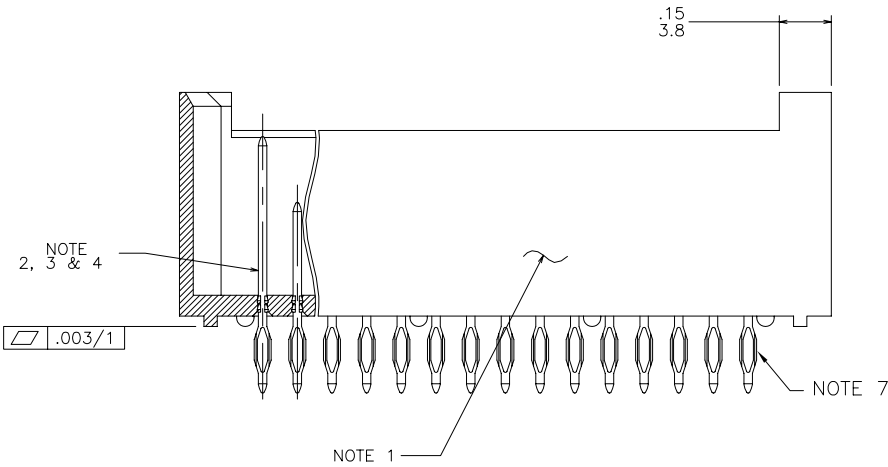
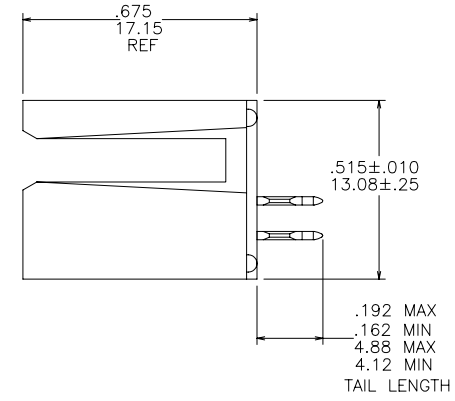
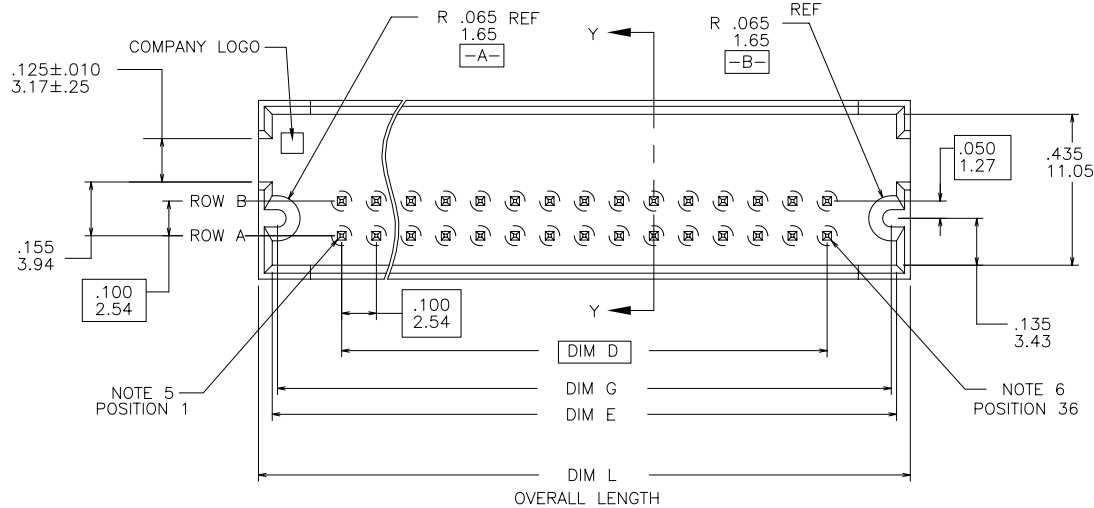

FCI
FCIconnect.com

Copyright FCI

mat'l. code		surface ISO 1302 ✓		tolerance ISO 406 ISO 1101		projection INCH/MM		product family HEADER	
ltr		ecn no		dr		date		title	
E		V61007		EPK		7/25/96		2 ROW GUIDE PIN HEADER, VERT	
F		V70823		SAR		6/3/97		(SLOTTED) SGL PIN ADVAN. GND.	
G		V01251		MDF		5/22/00		scale 2:1	
H		V21028		RGD		6/10/02		dr M. FETROW 11/21/94	
J		V03-0342		GJP		3/24/03		enr L. FYE 11/21/94	
K		M05-0089		ERE		5/20/05		chr L. FYE 11/21/94	
L		M07-0116		AGS		2/25/07		appd L. FYE 11/21/94	
sheet index		revision sheet		L		L		FCI	
				1		2		79839 A3	
								type Product Customer Drawing	

PRODUCT NO. NOTE 8	SIZE	OVERALL LENGTH DIM L	DIM D	DIM E	DIM G	DIM H ±.010/0.25	DIM J ±.010/0.25	GROUND PIN LOCATION
79839-001	2 X 11	1.48/37.6	1.000/25.40	1.40/35.6	1.37/34.8	.260/6.60	.450/11.43	LEFT-POSITION A-1
79839-002	2 X 11	1.48/37.6	1.000/25.40	1.40/35.6	1.37/34.8	.260/6.60	.450/11.43	RIGHT-POSITION A-11
79839-101	2 X 11	1.48/37.6	1.000/25.40	1.40/35.6	1.37/34.8	.260/6.60	.450/11.43	POSITIONS A-1 & A-11
79839-102	2 X 11	1.48/37.6	1.000/25.40	1.40/35.6	1.37/34.8	.318/8.08	.450/11.43	POSITIONS A-1 & A-11
79839-103	2 X 48	5.18/131.5	4.700/119.38	5.10/129.5	5.07/128.7	.320/8.1	.410/10.41	POSITIONS A-1,2,3,46,47,48

NOTES:

- ① MOLDING MATERIAL: HI-TEMP RESIN
PER UL 94 V-0.
COLOR: BLACK.
- ② TERMINAL MATERIAL: 3/4 HARD PHOS BRONZE
UNS C5100.
- ③ TERMINAL PLATING: 30u"/.76u GXT OVER
50u"/1.27u Ni.
- ④ PIN RETENTION TO BE 3 LBS / 1.36 KG
MIN PER PIN IN EITHER DIRECTION.
- ⑤ LOCATION OF ADVANCED GROUND PIN ON -001 PART,
POSITION A-1.
- ⑥ LOCATION OF ADVANCED GROUND PIN ON -002 PART,
POSITION A-11.
- ⑦ PRESS FIT PINS - USE ON (-1XX) PARTS ONLY.
- ⑧ ADD "LF" SUFFIX AT THE END OF PART NUMBER FOR LEAD FREE OPTION.
- ⑨ THESE PRODUCT MEETS EUROPEAN UNION DIRECTIVES AND OTHER
COUNTRY REGULATION AS DESCRIBED IN GS-22-008.
10. THE PRODUCT IS NOT INTENDED TO BE EXPOSED TO A MANUFACTURING
SOLDER PROCESS.
- ⑪ PLATING OPTIONS:
MAY BE EITHER GOLD OR GXT PLATED AT MANUFACTURER'S OPTION.

mat'l. code		surface ISO 1302 ✓		tolerance ISO 406 ISO 1101		projection 		product family HEADER	
ltr	ecn	no	dr	date	tolerances unless otherwise specified				
L					angles	linear	.XX±.01/.3	INCH/MM	
					0°±2'		.XXX±.005/.13	scale 2:1	
					dr	M. FETROW	11/21/94	dwg no	
					enr	L. FYE	11/21/94	sheet 2 of 2 size	
					chr	L. FYE	11/21/94	79839 A3	
					appd	L. FYE	11/21/94	type Product Customer Drawing	
sheet index	revision sheet								